

**NEW
LINE**

NASON

ENGINE PARTS



1300 662 766

OIL CONTROL VALVE FILTERS

PART NUMBER	FITMENT
OCVF 1	TOYOTA 1GR-FE <i>LANDCRUISER PRADO HILUX FJ CRUISER</i>
OCVF 2	TOYOTA 1MZ-FE 3MZ-FE <i>CAMRY AVALON KLUGER LEXUS</i>
OCVF 3	TOYOTA 1AZ-FE 2AZ-FE <i>RAV 4 AVENSIS CAMRY TARAGO ESTIMA RUKUS ALPHARD PREVIA</i>
OCVF 4	TOYOTA 1ZZ-FE 2NZ-FE <i>COROLLA YARIS ECHO PORTE</i>
OCVF 5	TOYOTA 1UZ-FE 2UZ-FE 3UZ-FE 2GR-FE 3GR-FSE 1JZ-GTE 2JZ-GE 1NZ-FE <i>LEXUS SOARER CELSIOR LANDCRUISER AURION KLUGER RAV 4 TARAGO</i>
OCVF 6	HYUNDAI KIA MITSUB ISHI 2.0L , 2.4L

Pictures not to scale
with each other



OCVF 1



OCVF 2



OCVF 3



OCVF 4



OCVF 5



OCVF 6

**NEW
LINE**

NASON

ENGINE PARTS



1300 662 766

OIL CONTROL VALVE FILTERS

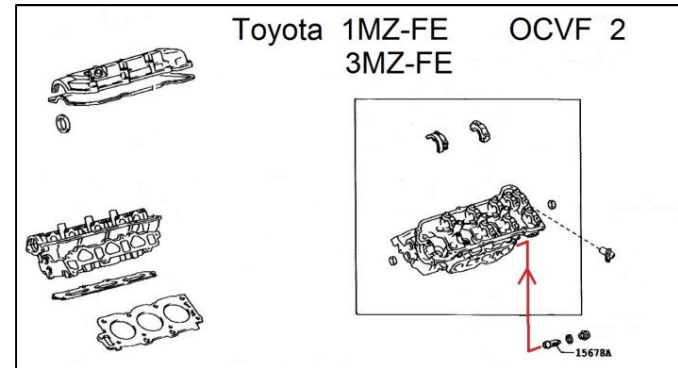
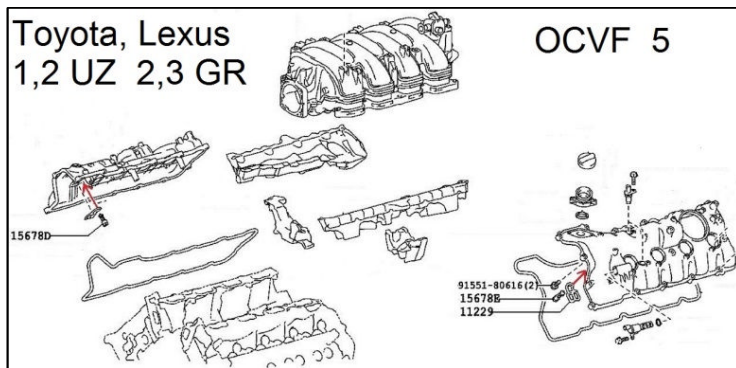
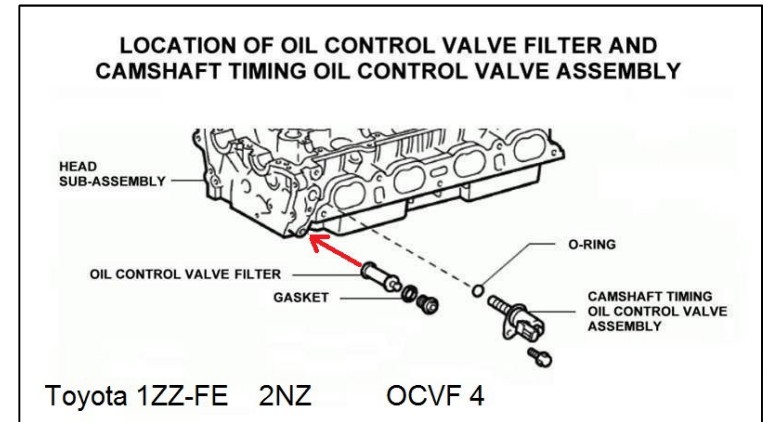
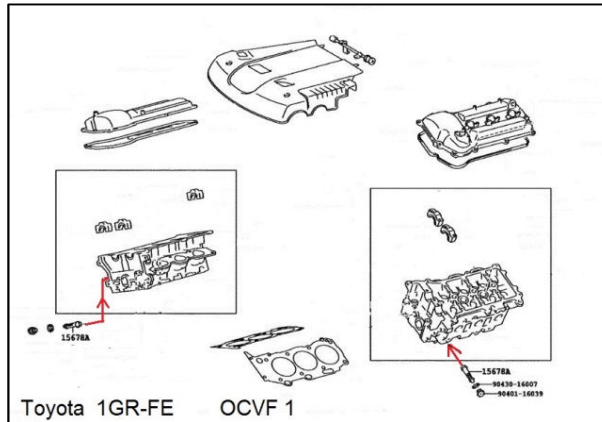
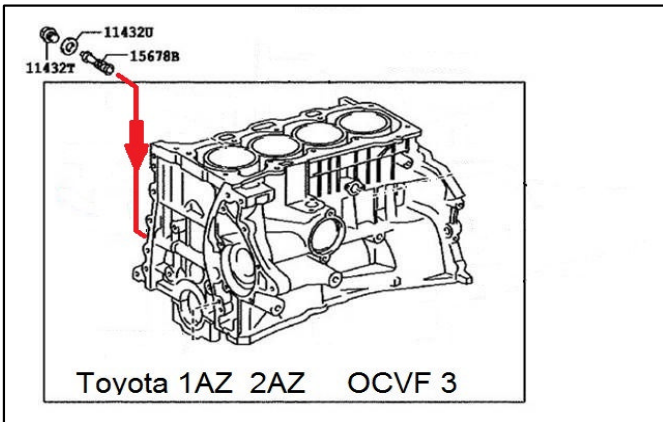

With the use today of Variable Cam Timing gears, many engines use OCV filters to keep impurities out of these critical timing components. A dirty or blocked OCV filter can cause incorrect operation even after a new timing kit has been installed.

These filters are generally found on the side of the cylinder head except for the Mitsubishi & Hyundai 2.0L & 2.4L which are found in the block under the cylinder head.