

Friction Discs or Diamond Washers For Crankshafts

Component downsizing and cost saving during manufacture has pushed vehicle manufactures to look for other ways of carrying out what used to be a simple undertaking. One example is the replacing of keyways.

On crankshafts or camshafts, the main bolts need to be firmly attached so that they can absorb any applied torque without slipping. Usually if we want to transfer greater torque, we need larger and therefore heavier and costlier components. However using a friction disc or washer in between the components locks them together firmly and allows for the transmission of four times the amount of torque.

These friction discs or washers are coated on both sides with a nickel matrix. The nickel is embedded with a fixed amount of diamond particles that have a specified size. If the disc is mounted between two engine parts, the hard diamond particles are pressed into the mating surfaces and locks them together.

To ensure the washer works reliably it is important to replace it whenever the connected components are removed or their positions disturbed.

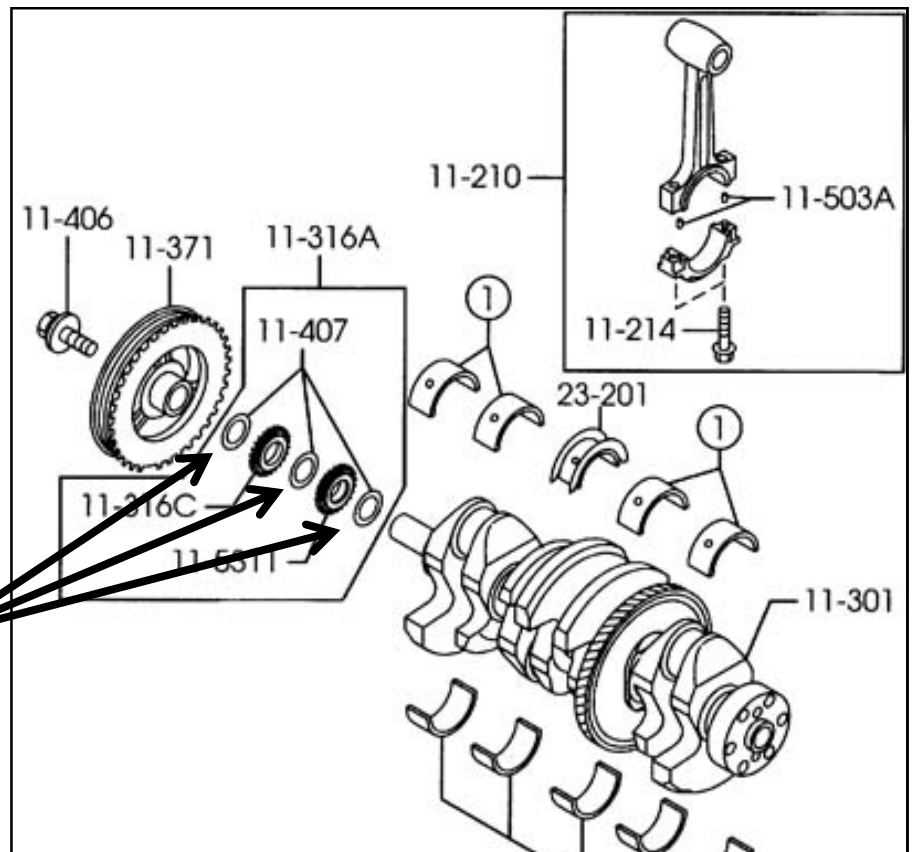

Our Part #

L3K9 -11- 407

**Suits MAZDA 3,6,CX-7 2.3L
DOHC 16V**

Crankshaft Friction Disc, 3 Required For Turbo Engines.
Crankshaft Friction Disc, 2 Required For Non Turbo Engines.

REFER TO THE MANUFACTURERS INSTRUCTIONS ABOUT WHETHER THE VEHICLE USES FRICTION DIAMOND WASHERS THAT NEED TO BE REPLACED.

WARNING

Because these washers and shims are located behind pulleys or sprockets they can easily fall when the larger part is removed. They could end up in the sump or jammed into an awkward spot without being noticed.